



# ANNUAL GENERAL MEETING

July 26, 2011

Toronto



# Disclaimer and Legal Notice



- This presentation includes certain “forward-looking statements.”
- All statements, other than statements of historical fact, are forward-looking statements that involve various risks and uncertainties. There can be no assurances that such statements will prove accurate and actual results and future events could differ materially from those anticipated in such statements.
- Such information contained herein represents management's best judgment as of the date hereof based on information currently available. The company does not assume the obligation to update any forward-looking statement.
- Nautilus Minerals Inc. ("Nautilus", "The Company"), all rights reserved. "Nautilus Minerals" and all logos used in this presentation are trademarks of Nautilus, unless otherwise noted. Nautilus © is a Registered Trade Mark. All graphics, effects, processes, information and data features in this presentation are owned or used under license by Nautilus, and public access is permitted for lawful personal information purposes only. Any use for any unlawful purpose, and any reproduction or dissemination, of any feature of this presentation in whole or in part, is strictly prohibited.
- No information in this presentation shall constitute an invitation to invest in Nautilus or any entities of the Nautilus Group. Neither Nautilus, nor the entities of the Nautilus Group, nor their respective officers, employees or agents, shall be liable for any loss, damage or expense however caused (including through negligence) which you may directly or indirectly suffer in connection with this presentation including, without limitation, any loss or profit, indirect, incidental or consequential loss. An offer to sell, or a solicitation of an offer to buy, securities of the Company can only be made by a broker registered in all jurisdictions in which such offer is being made, and only if such offer is otherwise made in accordance with all applicable securities laws, regulations and rules of any kind whatsoever.
- Nautilus shall not be responsible for any special, indirect, incidental or consequential damages that may arise from the use of the information from this presentation, irrespective of whether the information is provided by Nautilus.
- While efforts are made to keep the information in this presentation accurate and timely, neither Nautilus nor any of the entities of the Nautilus Group guarantee or endorse the content, accuracy or completeness of the information herein. The information within this presentation is provided in good faith on an "as is" basis, without representations or warranties of any kind, whether express or implied. For current information, contact Nautilus by e-mail ([investor@nautilusminerals.com](mailto:investor@nautilusminerals.com)).
- This information has been prepared to provide you with general information only. It is not intended to take the place of professional advice and you should not take action on specific issues in reliance on this information. In preparing this information, we did not take into account the investment objectives, financial situation or particular needs of any particular person. Should you wish to make any investment decision, you need to consider (with or without the assistance of an adviser) whether this information is appropriate to your needs, objectives and circumstances

# Chairman Geoff Loudon



# Share Price Rising Steadily



# CEO Steve Rogers



# Solwara 1 Mining Lease Granted

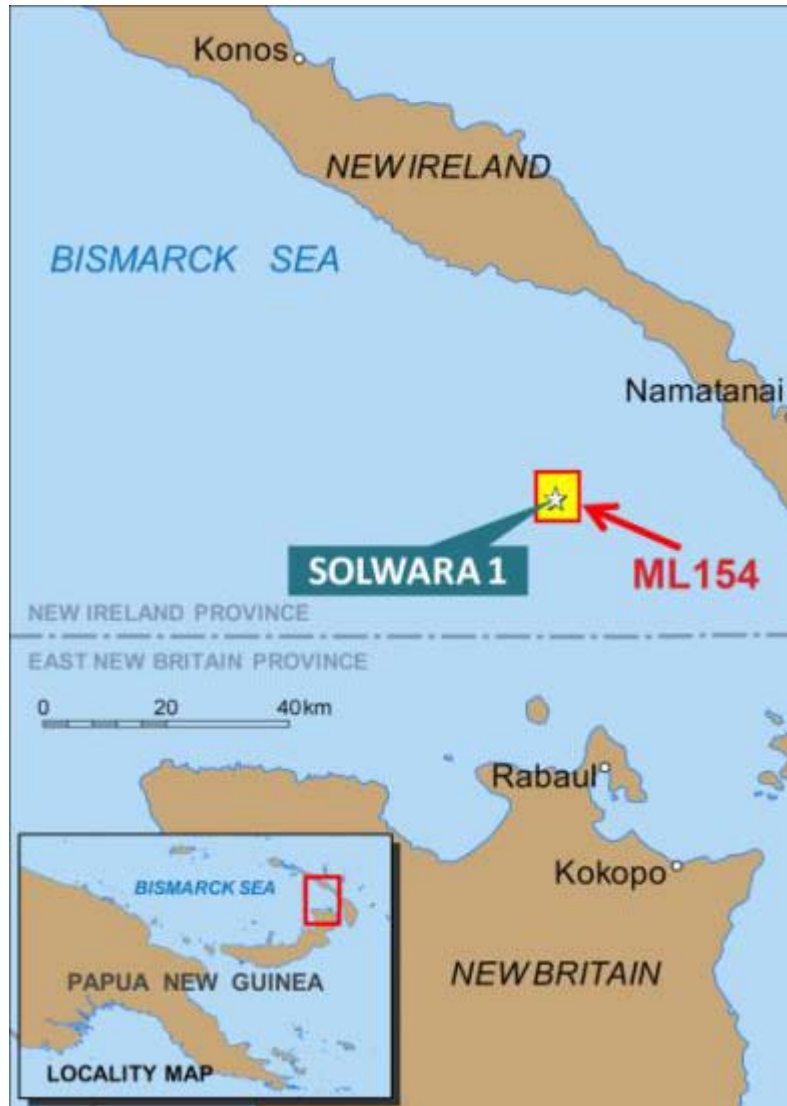

- Located in the Bismarck Sea, PNG, at 1600m water depth
- NI 43-101 Resource established
- Environmental permit granted Dec 2009
- Mining lease granted Jan 2011
- Resource remains open at depth

## Mineral Resources for Solwara 1

Classification	Domain	Tonnes	Cu (%)	Au (g/t)	Ag (g/t)	Zn (%)
Indicated	Massive Sulphide	870,000	6.8	4.8	23	0.4
Inferred	Chimney	80,000	11	17	170	6
Inferred	Lithified Sediment	2,000	4.5	5.2	36	0.6
Inferred	Massive Sulphide	1,200,000	7.3	6.5	28	0.4
<b>Indicated</b>	<b>Total</b>	<b>870,000</b>	<b>6.8</b>	<b>4.8</b>	<b>23</b>	<b>0.4</b>
<b>Inferred</b>	<b>Total</b>	<b>1,300,000</b>	<b>7.5</b>	<b>7.2</b>	<b>37</b>	<b>0.8</b>

Resource Estimate prepared by Ian Lipton, BSc (Hons), FAusIMM, Principal Geologist, Golder Associates Pty Ltd. Effective Date: 1 February 2008  
 Source: April 2011 Technical Report. Mineral Resources based on 4% cut-off grade

# Production Support Vessel



- JV with German shipping group Harren & Partner
- JV to build and own vessel chartered to Nautilus
- Operations base for seafloor production system
- Provides permanent access to state of the art vessel to maximise efficiency
- €127 million capital cost
  - €75 million debt to be procured by Harren
- 208 m x 40 m and 18,800 dwt
- 30 MW power station
- Accommodation for 160 staff
- Delivery to Singapore early 2013



# Seafloor Production Tools

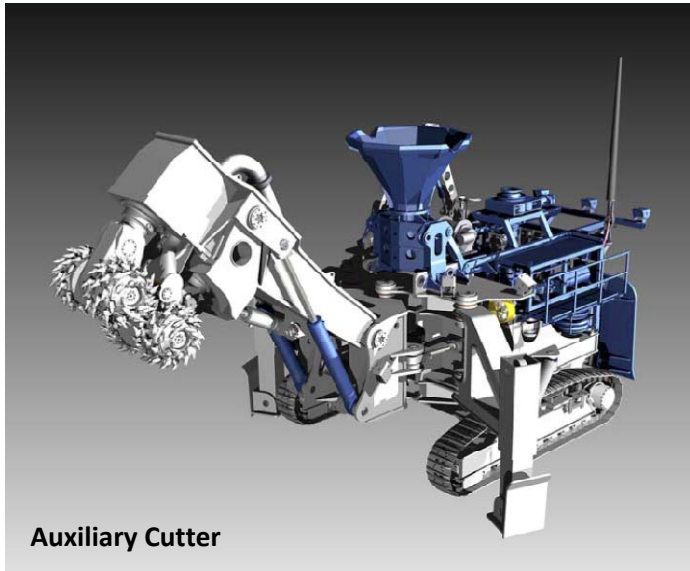
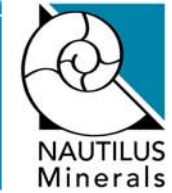

**Auxiliary Cutter**

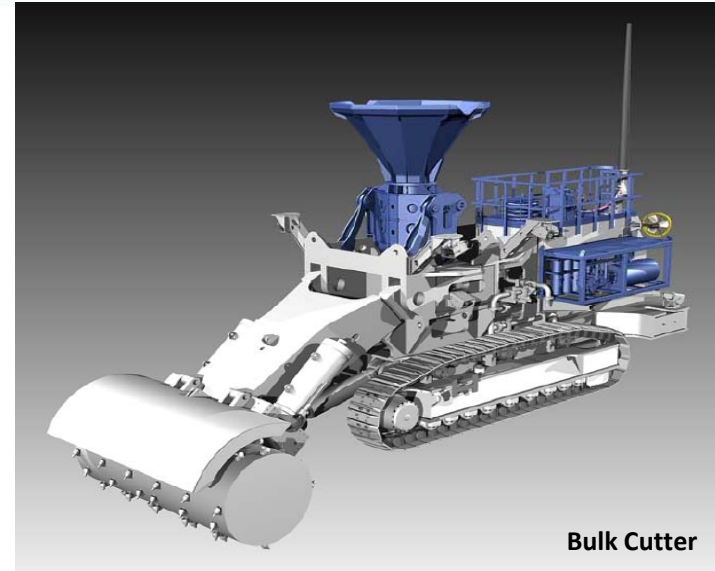

**Bulk Cutter**

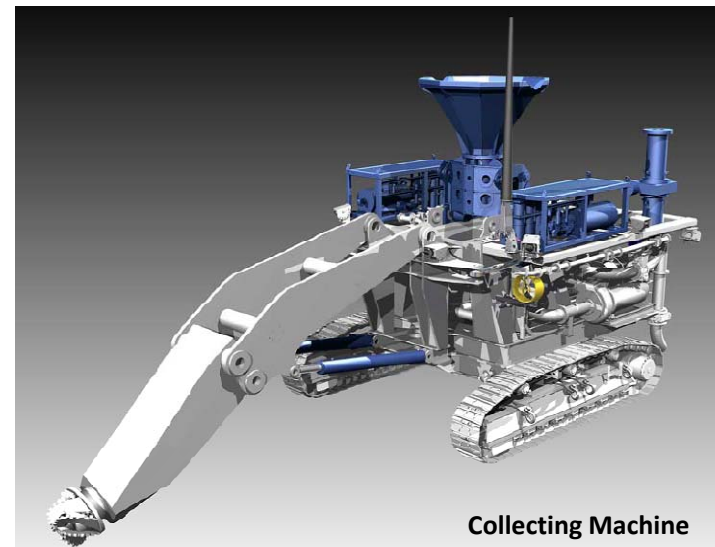

**Collecting Machine**

# Drilling Campaign



- 2011 Drilling Objectives
  - Increase understanding of the Solwara 1 Project resource
  - Drill at Solwara 5 and 12 including Solwara 1 North Zone
- Results From 2011 Campaign
  - Grades consistent with or better than 2007 program
  - High grade intercepts at Solwara 12
- Resource update by year end 2011



# Large Tenement Portfolio Established



- Total of 600,000 km<sup>2</sup> of tenements in multiple jurisdictions (1)

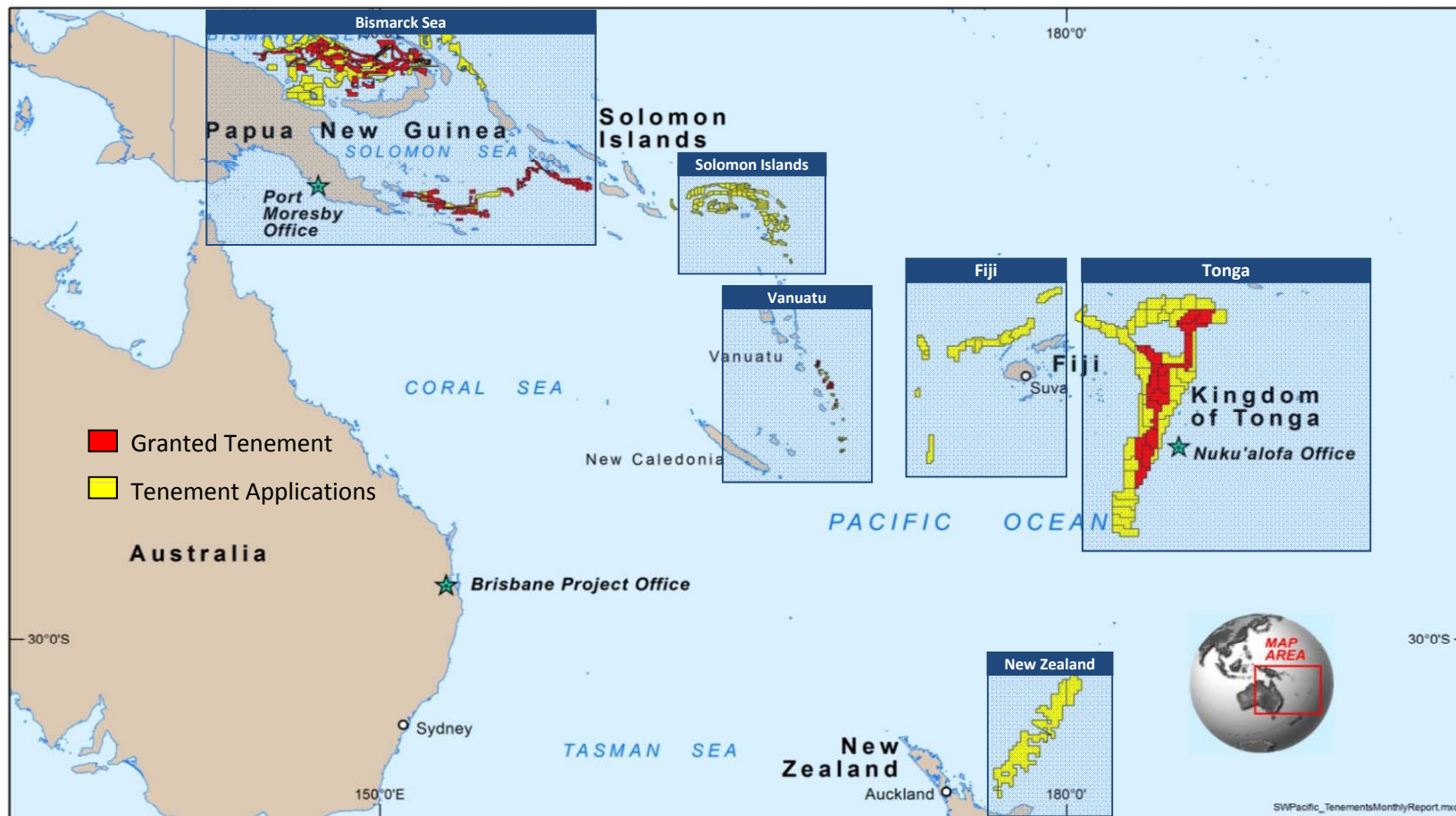

(1) Total tenements include those which have been granted and those under application. Includes 75,000 km<sup>2</sup> in Clarion-Clipperton Zone in Eastern Pacific

# Nautilus secures prize exploration territory

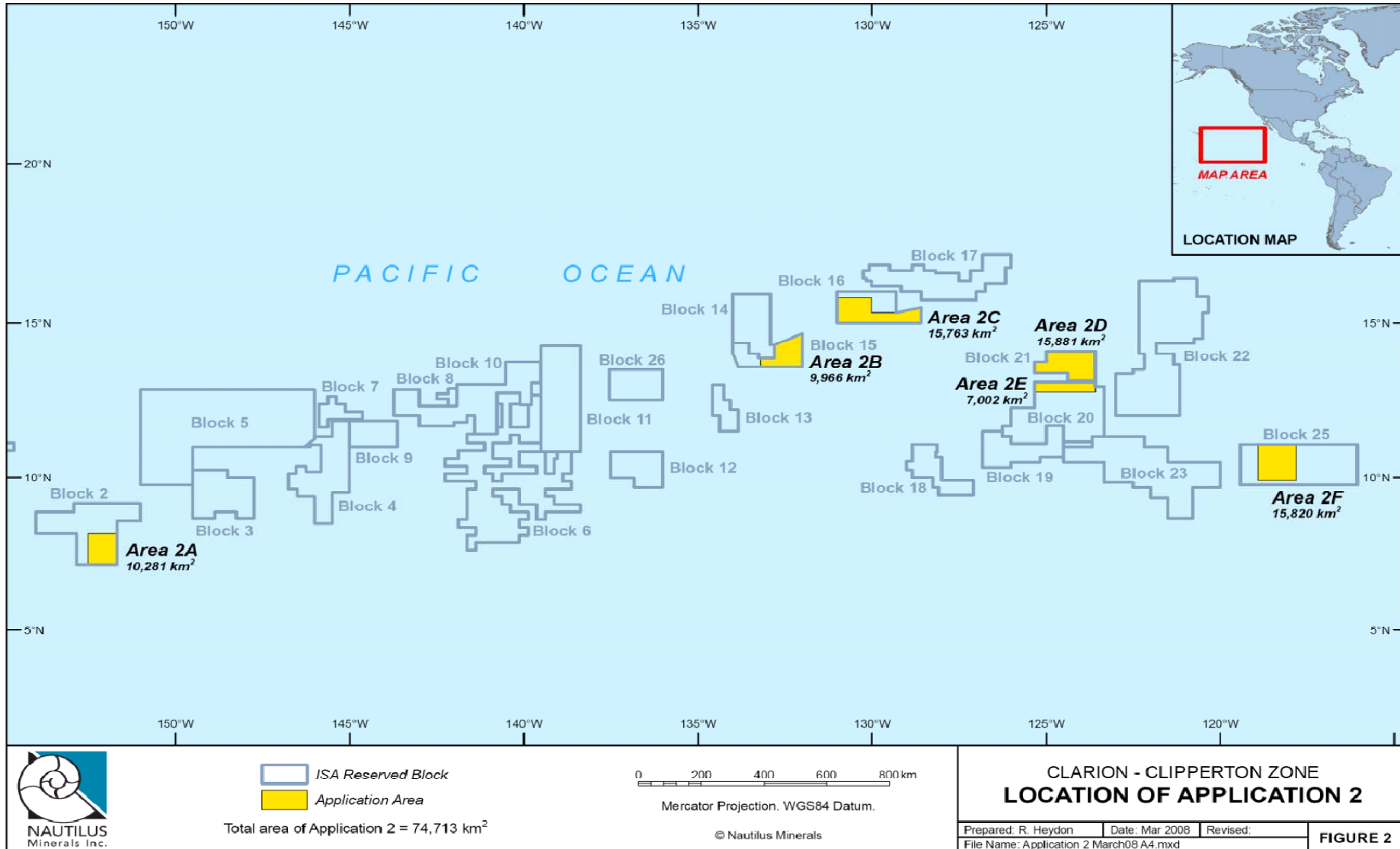

# 2010 AGM Priorities



- ✓ Secure strategic partnering arrangements
- ✓ Secure ML for Solwara 1
- ✓✗ Sanction project equipment build
  - ✓ Secure vessel
  - ✓ Drilling program
    - ✓ – Geotechnical data gathering
    - ✓ – Solwara 1 understanding
    - ✓ – Test new discoveries
  - ✓ Continue exploration
    - ✓ – Maintain tenements
    - ✓ – Fuel growth

# 2011 Priorities



- Update resource
- Complete financial arrangements with PNG Government/Petromin
- Implement revised capital plan, secure additional funding
- Advance equipment construction
  - Take delivery of cutting heads
  - Complete initial slurry test program
  - Commence vessel steel fabrication
- Target generation exploration program in PNG, Tonga
- Secure additional exploration licences
  - Fiji
  - New Zealand
- Close out initial marketing deal

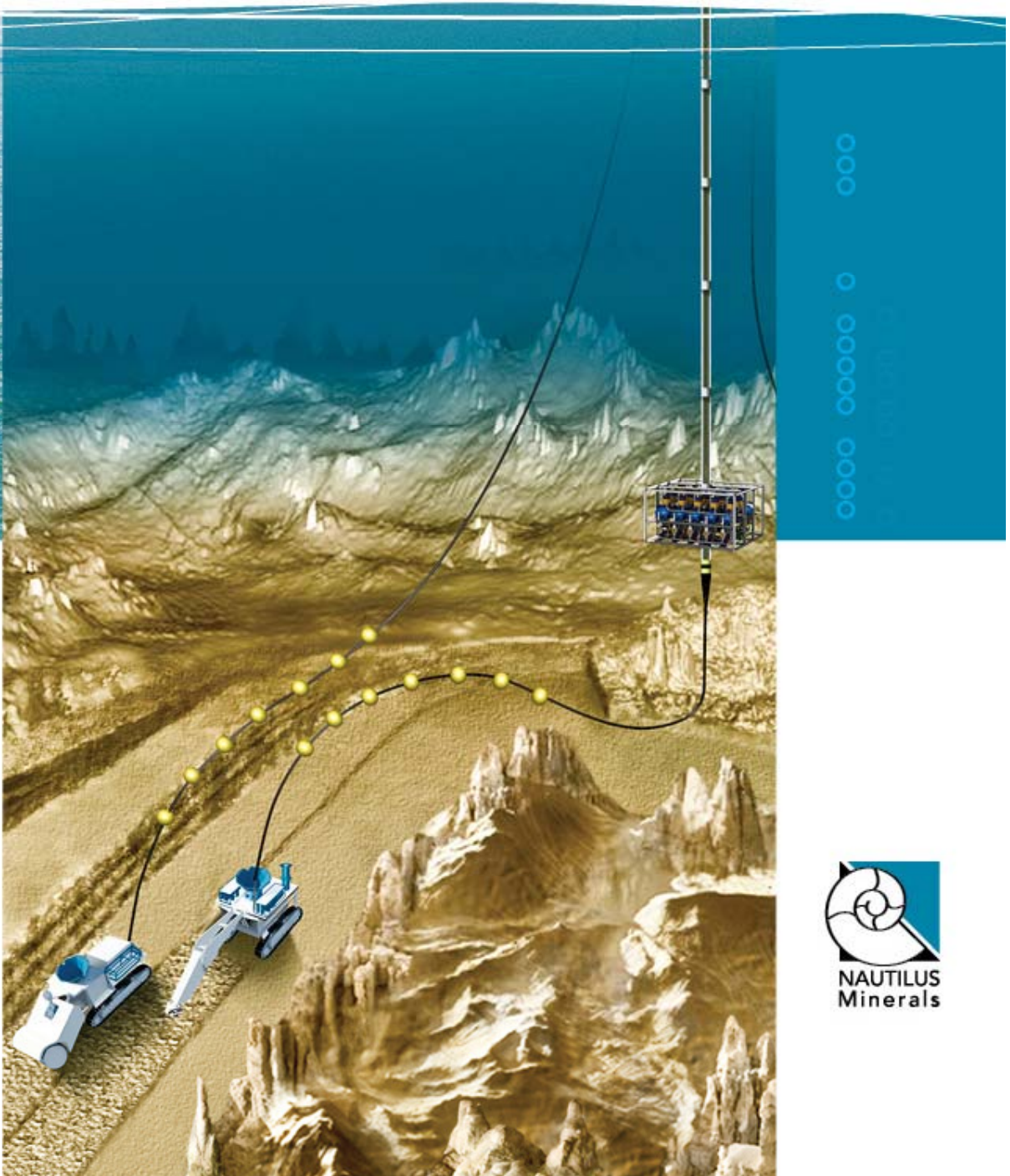

Steve Rogers - CEO  
[investor@nautilusminerals.com](mailto:investor@nautilusminerals.com)

[www.nautilusminerals.com](http://www.nautilusminerals.com)

